

## Single-Track Digital Playback Module

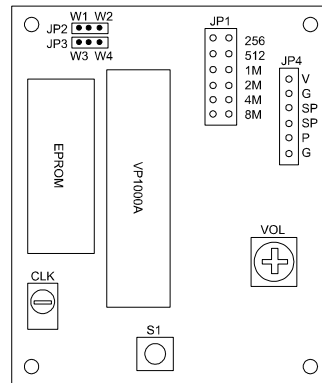

- **Operation Mode:** playback only
- **Max. Number of Tracks:** 1
- **Memory Type:** EPROM
- **Max. Memory Capacity:** 1MB (27C080)
- **Max. Audio Length:**  
4 minutes @ 32 kbps  
2 minutes @ 64 kbps
- **Supply Voltage:** 9-12 VDC
- **Typical Operating Current:** 300mA
- **Max. Audio Output:** 1.5W (8 Ohm load)
- **Battery Operation:** not suitable
- **Physical Dimensions:** 2.5" x 3.0"

### General Description

DM1000B is an EPROM-based digital playback board capable of playing back a QuikVoice sound file of up to 1MB. It is totally self-contained and requires only a DC power supply, a speaker, and a triggering device to operate.

Sound programming can be accomplished in two steps. The first step is to digitize the audio into a QuikVoice file by using either the VP880 development system or our digitization service. The second step is to program the QuikVoice file into an EPROM chip by using a standard EPROM programmer, and then installed the chip into a socket on the module. EPROM chips are nonvolatile so battery backup is unnecessary.

DM1000B supports sampling rates ranging from 32 to 64 kbps, allowing the user to choose an optimum price/performance trade-off for his application. The 32 kbps sampling rate is suitable for most voice-only applications, while the 64 Kbps sampling rate is preferred for musical applications.

Audio playback can be activated by shorting the trigger input to the ground momentarily. This can be accomplished by using a push button, a relay closure, a PLC output, or a motion sensor (such as SU20). The trigger input is ignored when DM1000B is playing. If the input is shorted to the ground when the playback ends, the sound will restart.

With a maximum output power of 1.5W when driving an 8 Ohm speaker, DM1000B is not very suitable for battery operation due to its high power consumption. Note that the output is balanced, not single ended.

### Installation Guide

#### Interface Connector: JP4

V: Input voltage  
G: Ground (two pins)  
SP: Speaker (two pins)  
P: Trigger input

#### EPROM Type Jumpers: JP1, JP2, JP3

These jumpers must be set according to the following table.

TYPE	JP1	JP2	JP3
27C256	256	W1	W3
27C512	512	W1	W4
27C010	1M	W2	W4
27C020	2M	W2	W4
27C040	4M	W2	W4
27C080	8M	W2	W4

#### Volume Control: VOL

#### Sampling Rate Adjustment: CLK

If the audio sounds too fast or too slow, adjust the sampling rate till it sounds right. With a frequency counter, the sampling rate can be measured at pin 19 of the VP1000A chip while the audio is playing.

#### Test Button: S1

Press this button to activate the playback for testing purpose.